

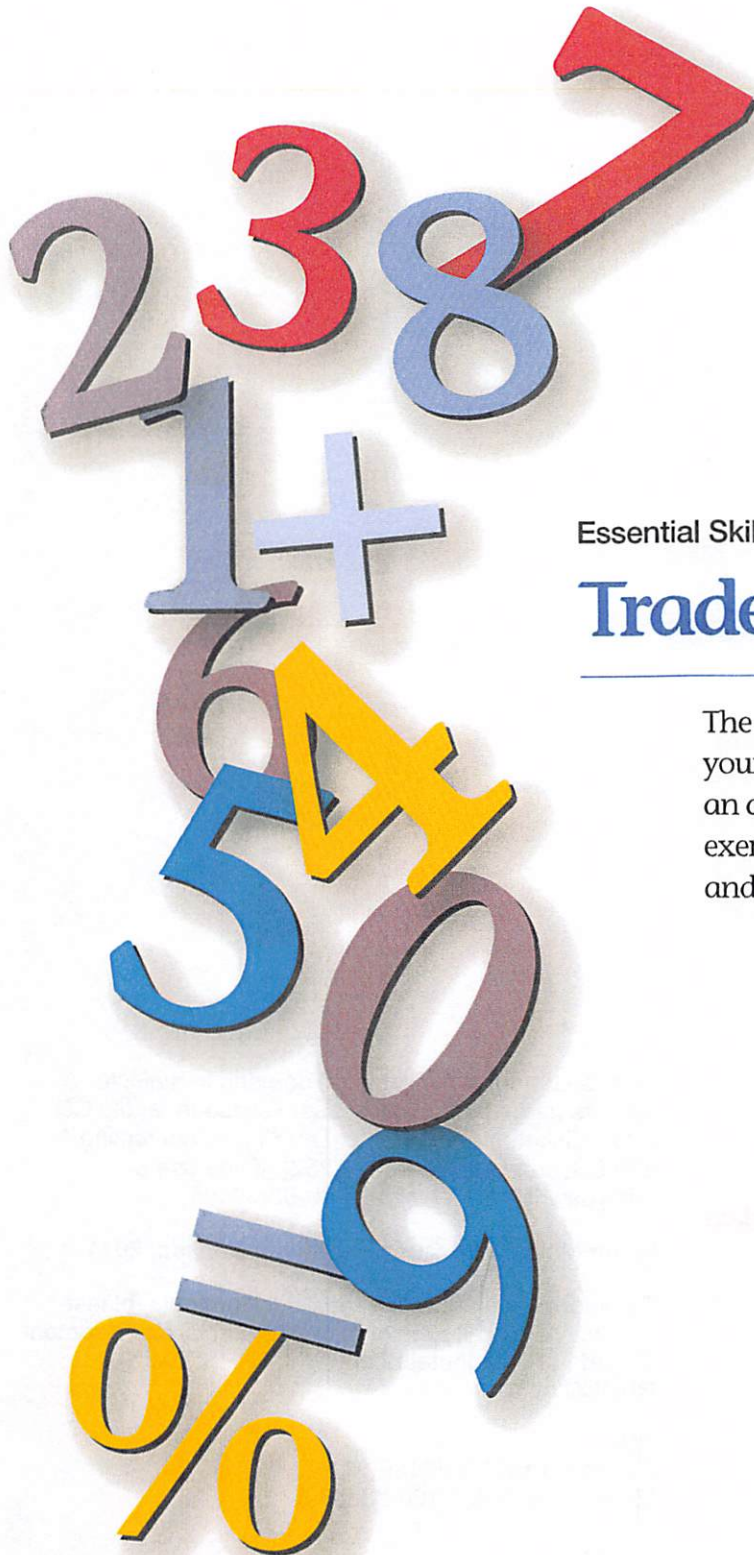

Now and Tomorrow
Excellence in Everything We Do



Essential Skills and Apprenticeship

Trades Math Workbook

The *Trades Math Workbook* will help you improve your numeracy skills and increase your success in an apprenticeship program. It includes a variety of exercises to help you practise your numeracy skills and learn how these skills are used in the trades.



You can download this publication by
going online: <http://www12.hrsdc.gc.ca>

For more information on the Interprovincial
Standards Red Seal Program, visit www.red-seal.ca

This document is available on demand in multiple
formats (large print, Braille, audio cassette, audio CD,
e-text diskette, e-text CD, or DAISY), by contacting 1
800 O-Canada (1-800-622-6232). If you use a
teletypewriter (TTY), call 1-800-926-9105.

© Her Majesty the Queen in right of Canada, 2014

For information regarding reproduction rights, please
contact via e-mail Employment and Social Development
Canada at [droitdauteur.copyright@HRSDC-
RHDCC.gc.ca](mailto:droitdauteur.copyright@HRSDC-RHDCC.gc.ca)

PDF

Cat. No.: Em16-2/2014E-PDF
ISBN/ISSN: 978-1-100-23383-3

ESDC

Cat. No.: WP-145-03-10E



Table of Contents

Introduction	4
Math Foundations	5
Section 1: Measurement and Calculation	7
Using Measuring Tools	7
Using Formulas	9
Using Drawings	15
Estimating Weight Loads	17
Working with Quantities	18
Section 2: Money Math	20
Calculating Increases and Decreases	20
Invoicing for Services	21
Section 3: Scheduling, Budgeting and Accounting	23
Comparing Values	23
Accounting for Cost	25
Section 4: Data Analysis	27
Calculating Tolerances	27
Using Numbers in Patterns	28
Answer Key	29



Introduction

Working in the trades requires strong numeracy skills to help you succeed on the job. This workbook includes questions and learning material to help you:

- learn more about the numeracy skills required to work in the trades;
- discover how journeypersons use numeracy on the job;
- practise your numeracy skills; and
- find out which numeracy skills you may need to improve.

The workbook is divided into four sections, each of which highlights different numeracy skills that journeypersons use on the job.

1. Measurement and calculation:

Skills used to measure and describe the physical world, for example by taking measurements and calculating area and volume.

2. Money math:

Skills used in paying and receiving money on the job, for example in handling cash, making change, preparing bills or making payments.

3. Scheduling, budgeting and accounting:

Skills used to manage time and money, for example in planning and keeping track of how you use your time and money, in choosing the products or services that offer the best value and in using your time and money wisely.

4. Data analysis:

Skills used to solve problems by analyzing and comparing numerical data.

An answer key is provided at the end of the workbook to help you review your answers and find out which areas of numeracy you may need to improve.

Math Foundations

Trades occupations require all or most of the math foundations listed below.

Math foundation skills		Workplace examples
Whole numbers e.g.: 3, 14	Read, write, count, round off, add, subtract, multiply and divide whole numbers.	<ul style="list-style-type: none"> • Order supplies. • Take stock inventory. • Count parts. • Read serial numbers.
Integers e.g.: -5, 0, 11	Read, write, add, subtract, multiply and divide integers.	<ul style="list-style-type: none"> • Read temperatures. • Use survey tools. • Set up computer numerical control programs. • Measure air pressure.
Fractions e.g.: $\frac{1}{8}$, $\frac{1}{4}$	Read, write, round off, add, subtract, multiply or divide fractions. Multiply or divide by a fraction.	<ul style="list-style-type: none"> • Take and record imperial measurements. • Determine tool or material sizes. • Calculate quantities.
Decimals e.g.: 8.50, 0.00375	Read, write, round off, add or subtract, multiply or divide decimals. Multiply or divide by a decimal.	<ul style="list-style-type: none"> • Handle money. • Take and record metric measurements. • Measure tolerances. • Select tool sizes.
Percentages e.g.: 10%, 42%	Read and write percentages. Calculate the percentage one number is of another. Calculate a percentage of a number.	<ul style="list-style-type: none"> • Calculate tax. • Read and write tolerances. • Adjust machine loads. • Describe in terms of a proportion of maximum capacity or an amount of progress towards completion.
Equivalent numbers e.g.: $\frac{1}{2} = 0.5 = 50\%$	Convert between fractions, decimals and percentages.	<ul style="list-style-type: none"> • Convert decimal readings on gauges to percent of output. • Convert decimals to fractions to select the correct part or size of tool. • Convert quantities of ingredients to decimals to calculate cost.
Other real numbers e.g.: $\sqrt{36}$, 9^2 , 2.2×10^3 , π	Use square roots, powers, scientific notation and significant digits.	<ul style="list-style-type: none"> • Calculate power and current in three-phase motors. • Use square roots to calculate dimensions for a staircase. • Use powers to express the volume of tanks.
Equations and formulas	Solve problems using equations with one unknown quantity. Use formulas by inserting quantities. Solve quadratic equations.	<ul style="list-style-type: none"> • Determine where to place holes. • Calculate the correct angles for rigging loads. • Set food prices. • Use Ohm's law to check motor voltage.

Math foundation skills		Workplace examples
Rates, ratios and proportions	Use a rate comparing two quantities with different units. Use a ratio comparing two quantities with the same units. Use a proportion comparing two ratios or rates.	<ul style="list-style-type: none"> • Adjust tire pressure. • Mix gasoline additives. • Adjust ingredients in a recipe to make more servings. • Calculate speed and feed rates of a machine. • Read a scale drawing. • Calculate airflow rates.
Measurement conversions	Convert between imperial and metric (SI) measurements. Convert to another unit within a measurement system.	<ul style="list-style-type: none"> • Convert units to select wrench sizes. • Cut lengths of wire. • Mix colouring agents. • Meet product specifications. • Calculate airflow. • Use scale drawings.
Areas, perimeters and volumes	Calculate areas, perimeters and volumes.	<ul style="list-style-type: none"> • Calculate the area or perimeter of a work surface to be painted, sodded or caulked. • Calculate the volume of gasoline additives or concrete required. • Calculate the capacity of a storage tank.
Geometry	Apply geometric concepts such as parallelism, perpendicularity and tangents.	<ul style="list-style-type: none"> • Find the centre of a room to install fixtures. • Cut hair using angles. • Cut slopes to fabricate ramps. • Use angles to lay out patterns for materials.
Trigonometry	Use trigonometry to determine the size of an unknown side or angle of a triangle.	<ul style="list-style-type: none"> • Calculate angles for a circular staircase. • Place holes on a part. • Make bolt patterns for drilling or machine installation. • Find offsets.
Summary calculations	Calculate averages and rates other than percentages, proportions or ratios.	<p>Calculate averages for:</p> <ul style="list-style-type: none"> • fuel or power consumption; • tool lifespan; • speed and feed rates; • material production; and • time needed to perform tasks.
Statistics and probability	Use statistics and probability to draw conclusions.	<ul style="list-style-type: none"> • Estimate how much of something clients use. • Predict sales trends. • Determine the probability of equipment and parts failure. • Describe the progress of fabrication and installation tasks.



Section 1: Measurement and Calculation

Measurement is the way that numbers are used most often in the trades. Measurement and calculation are used to measure and describe the physical world, for example by taking measurements and calculating area and volume. The following are three typical workplace examples of measurement and calculation:

- **Construction electricians** take measurements and perform calculations to make sure that electrical installations meet electrical code requirements.
- **Carpenters** take precise measurements using survey equipment.
- **Plumbers** perform calculations using trigonometry to design, fabricate and install pipe that needs to go around an obstacle.

Using Measuring Tools

Journeypersons who build things in their work use measuring tapes, laser survey equipment, micrometers, scales and other tools to measure on a daily basis. They work with both imperial and metric measurements on the job.

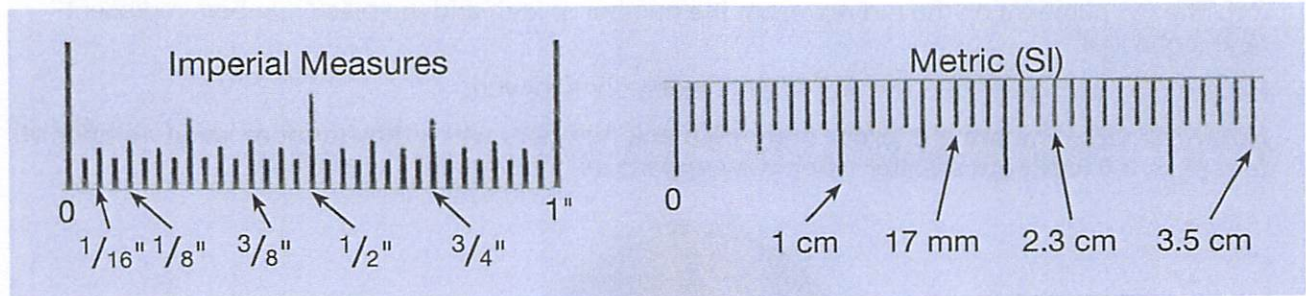

1. Enter the correct length beside each arrow on the measuring tape. Remember to include the correct unit (inches or centimetres). Two examples are provided for you.

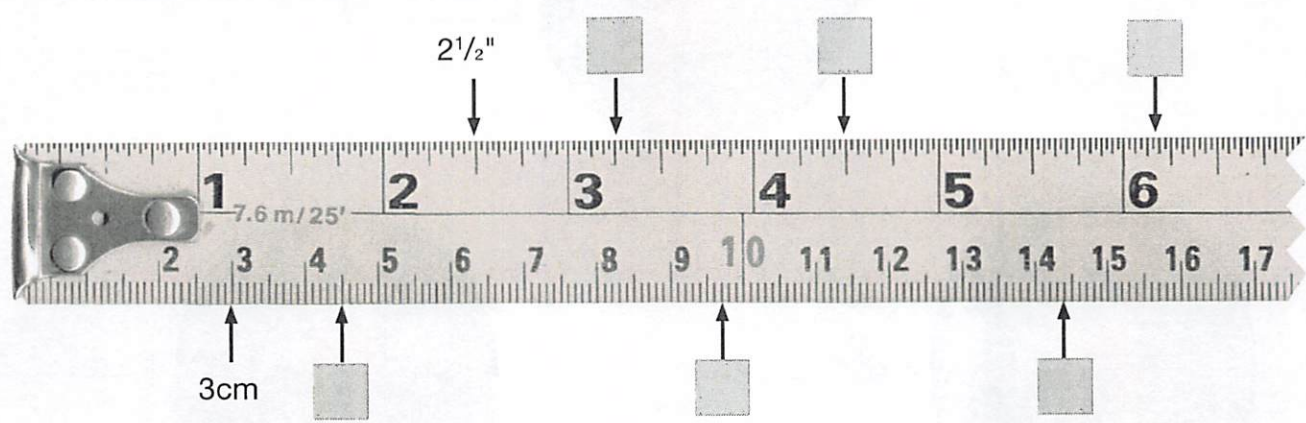

2. Label the following measurements (a–f) on the measuring tape with an arrow and the letter of the question. Two examples have been done for you.

x. $37\frac{1}{2}$ "

y. 1.01m

a. $39\frac{1}{8}$ in.

d. 93 cm

b. 3 ft. $4\frac{3}{4}$ in.

e. 0.992 m

c. 3.5 ft.

f. 107.5 cm

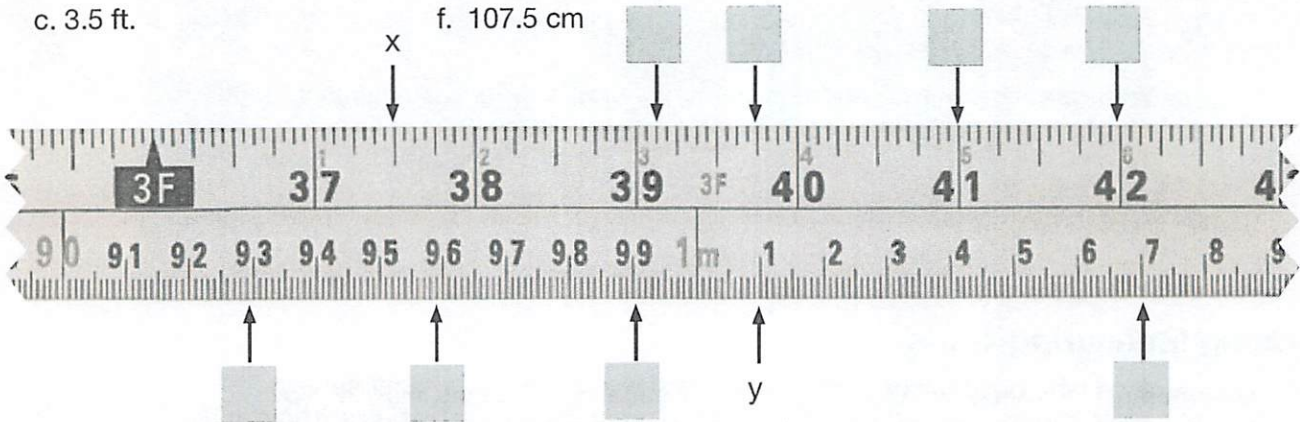

3. **Carpenters** take readings of elevations, directions and lengths of property lines using a levelling rod. The red numbers on the rod represent the number of feet, and the black numbers represent tenths of a foot.



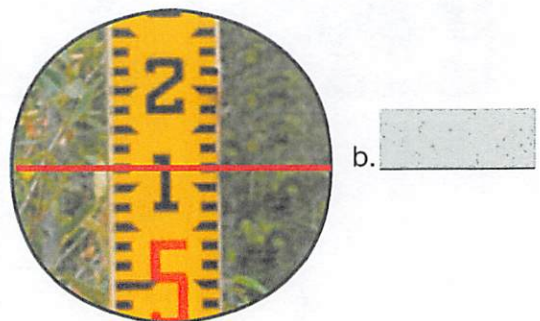
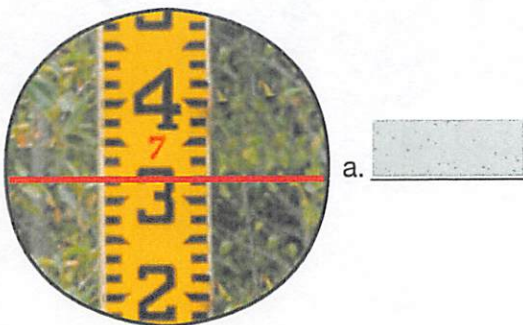
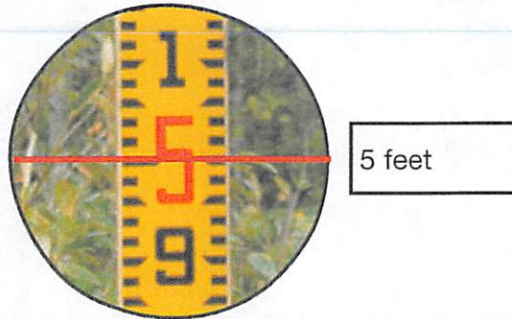

Record the readings below. The first one has been done for you.

Note: The red numbers are larger than the black numbers when they mark an even number of feet (e.g., 3.0 feet), but smaller when they appear as “reminders” in between.

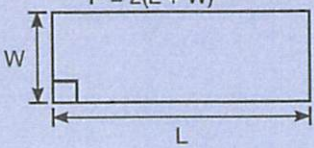
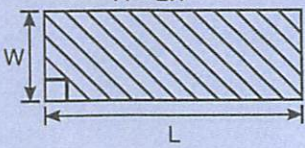
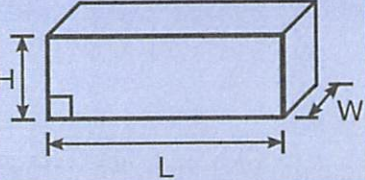
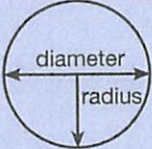

Using Formulas

The formulas in the box below will help you solve the workplace problems in this section.

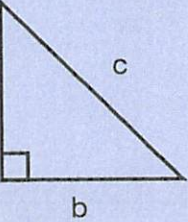
Formulas for Perimeter, Area and Volume		
Perimeter	Area	Volume
1 - Dimensional $P = 2(L + W)$ 	2 - Dimensional $A = LW$ 	3 - Dimensional $V = LWH$ 
$C = \pi d$ or $C = 2\pi r$ radius = $\frac{\text{diameter}}{2}$ diameter = $2 \times \text{radius}$ 	 $A = \pi r^2$ L.A. = πdh or L.A. = $2\pi rh$ S.A. = L.A. + area of both bases 	 $V = \pi r^2 h$ $V = \frac{\pi r^2 h}{3}$ 
Pythagorean Theorem (3-4-5 Method) $a^2 + b^2 = c^2$ $a^2 = c^2 - b^2$ $b^2 = c^2 - a^2$ 	If your calculator doesn't have a π key, use 3.1416.	

Whether you are in a classroom or on the job, it is helpful to develop your own method for solving math problems involving measurements. The steps below can help you do this.

Steps:

1. Draw a diagram and label it with measurements.
 - Identify the information you need.
 - Think about the units you are working with (e.g., square metres, loads, feet).
2. Decide which formula or formulas you will need to use.
3. Calculate the answer.

Note:

Use your calculator to complete the questions in this workbook.



When you're on the job, using a calculator saves time. Become familiar with your calculator so that you can use all of its features.

1. A **carpenter** is building a temporary fence around a building site. How many metres of fencing are required for a site that is 47.8 m × 30.3 m? Round your answer up to the nearest metre.

Use the problem-solving steps:

1. Draw
2. Decide
3. Calculate

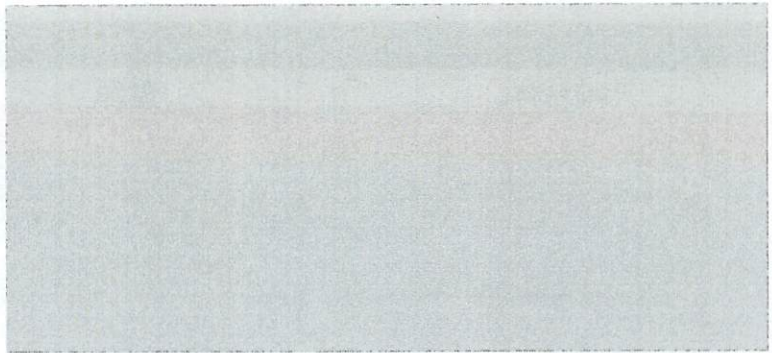

2. How many studs will a **carpenter** need to frame the exterior walls of the building below? Use the formula given below to estimate the number of studs.

$$\text{Number of studs} = \frac{\text{perimeter}}{2}$$

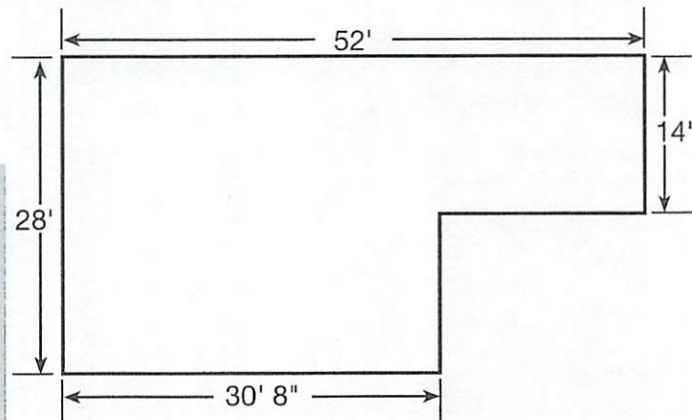

3. How many 3.7 L containers of bonding product does a **floorcovering installer** need to install vinyl sheet flooring in a room measuring 9.2 m × 7.8 m?

Only full containers can be ordered.

Typical Recommended Trowel (depth, width, space)	Approximate Coverage	Trowel
Fibrous felt-backed vinyl sheet goods: $\frac{1}{32}'' \times \frac{1}{16}'' \times \frac{1}{32}''$ (0.8 mm × 1.6 mm × 0.8 mm)	185–245 sq. ft./U.S. gal. (4.5–6.0 m ² /L)	

4. A **bricklayer** is covering a playground surface with rubber tiles. Each 2-ft.² tile costs \$13.29. Calculate how much it will cost to cover the playground.

Note: Only whole tiles can be ordered, so you will need to round your answer up when you calculate how many tiles are needed.

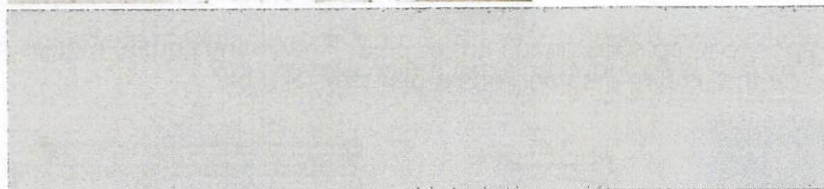
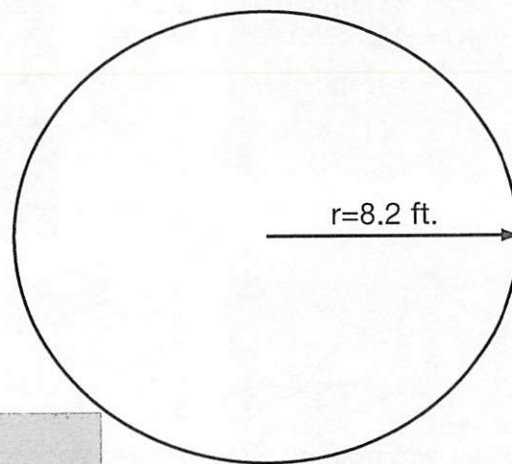

5. A **landscape horticulturalist** needs to order enough sand to create a border 152 mm deep around a square surface, as shown below. How many cubic metres of sand are needed?

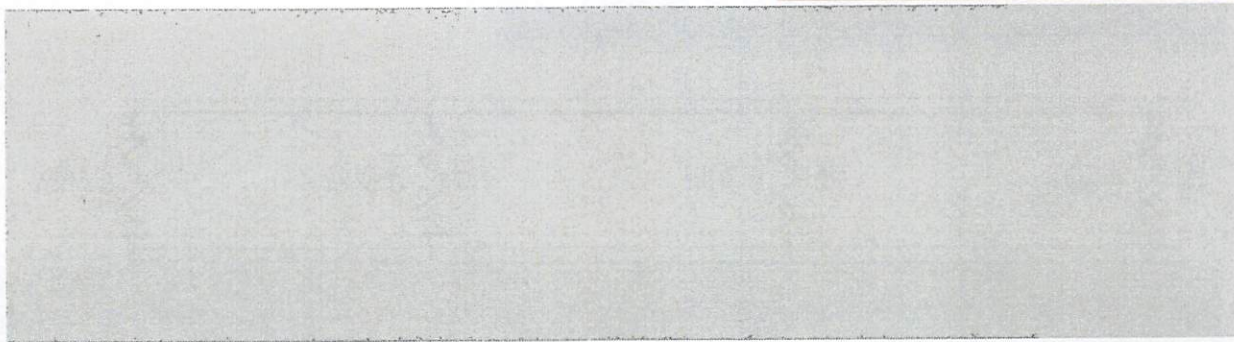
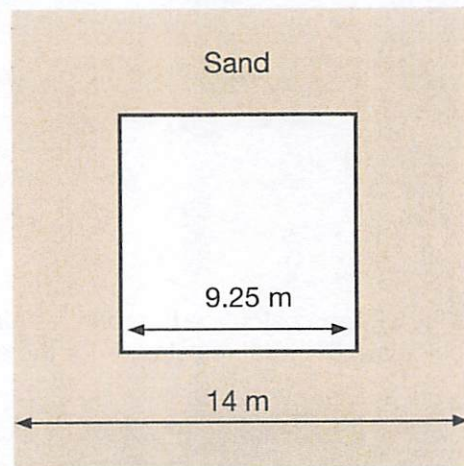

6. A **construction craft worker** needs to know how much material is in the cone-shaped pile shown below. Calculate the approximate volume of the pile in cubic yards.

Use this formula to calculate the radius of a pile of material:

$$r = \frac{3}{4} \times \text{height}$$

$$27 \text{ ft.}^3 = 1 \text{ yd.}^3$$

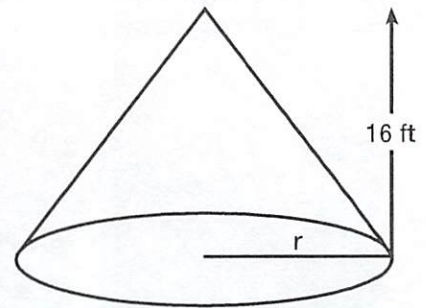

7. **Heat and frost insulators** cover pipes to keep substances hot or cold. How many square metres of material are needed to insulate a pipe that is 6 m long and has a diameter of 2 m?

Think of the cylinder as being laid out flat so that the circumference becomes the width measurement.

Use this formula: πdh

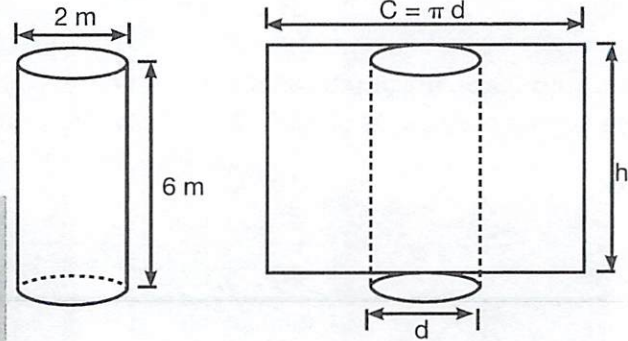

8. **Electricians** calculate the total resistance of parallel electrical circuits. Use the formula below to calculate the total resistance for the circuit shown.

Total resistance = $\frac{\text{resistance of one resistor (ohms)}}{\text{number of resistors}}$

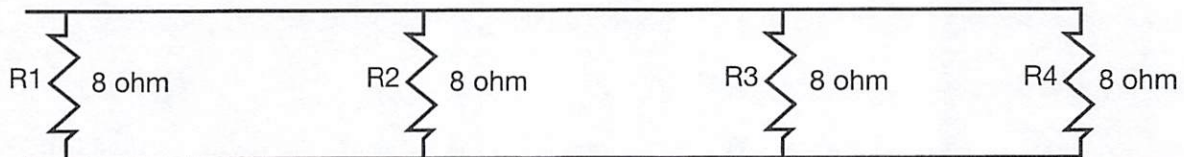

9. **Plumbers** fit pieces of pipe for custom jobs. What is the centre-to-centre (c-c) length of the pipe shown below?

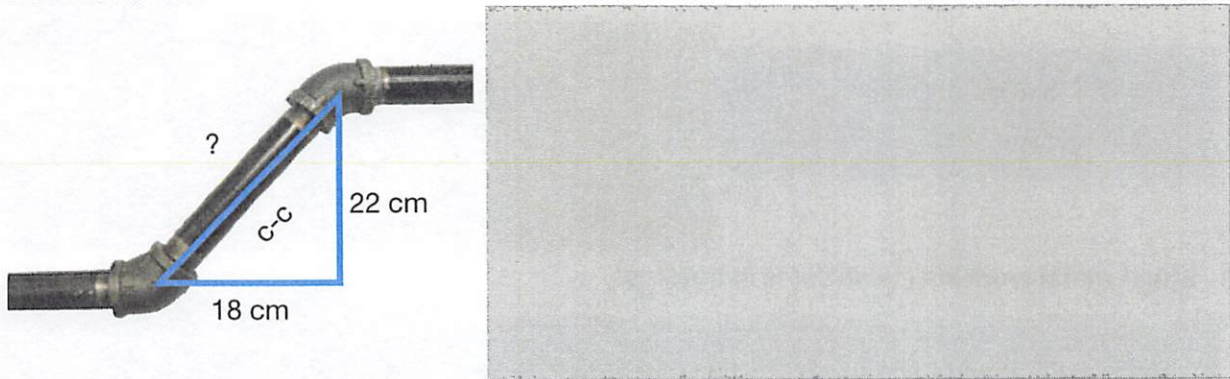

10. **Carpenters** perform calculations to help them lay out and construct wooden stairs. Calculate the length of the stringer (c) for the stairs shown below.

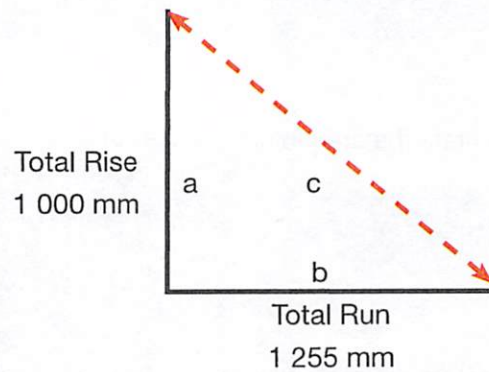
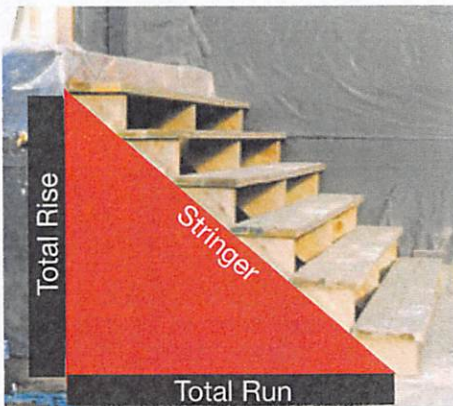

11. **Refrigeration and air conditioning mechanics** and **sheet metal workers** build and install transition elbows to connect different sizes of ducts. Calculate the length of the diagonal side of the transition elbow shown below.

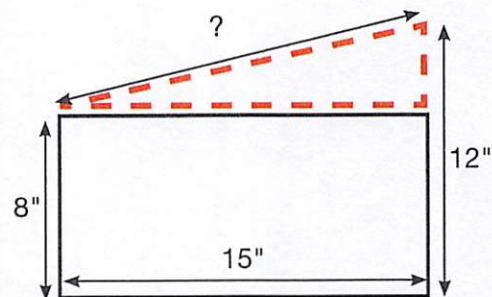
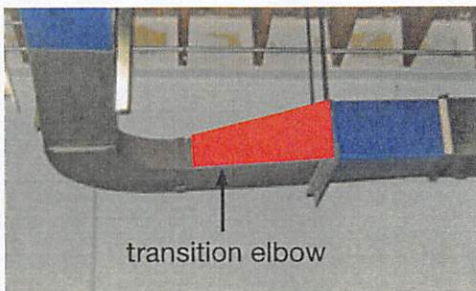

12. **Plumbers** calculate water pressure in pounds per square inch (psi). What is the water pressure for a 28-foot vertical pipe full of water?

Use this formula:

$$\text{Water pressure (psi)} = h \times 0.433$$

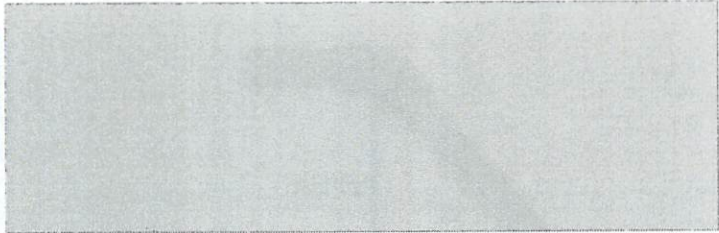

13. **Sheet metal workers** install ducts in buildings.

The equation below shows the relationship between:

- airflow volume in cubic feet per minute (V);
- air velocity in feet per minute (v); and
- area of a cross-section of duct in square feet (A).

$$V = A \times v$$

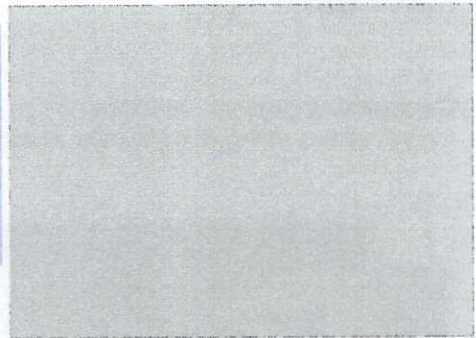

a. Calculate the area in square feet of a cross-section of an 8 in. \times 24 in. duct.

$$1 \text{ ft.}^2 = 144 \text{ in.}^2$$

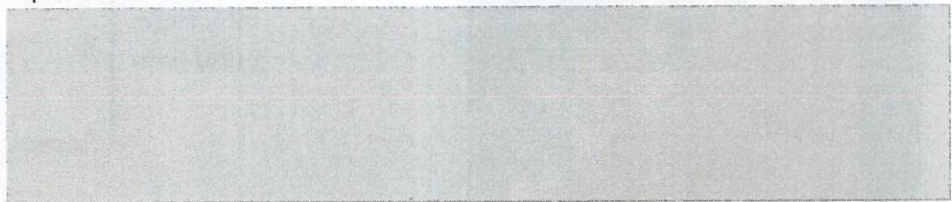

b. Calculate the airflow volume if the air velocity in the same duct is 1 200 feet per minute.

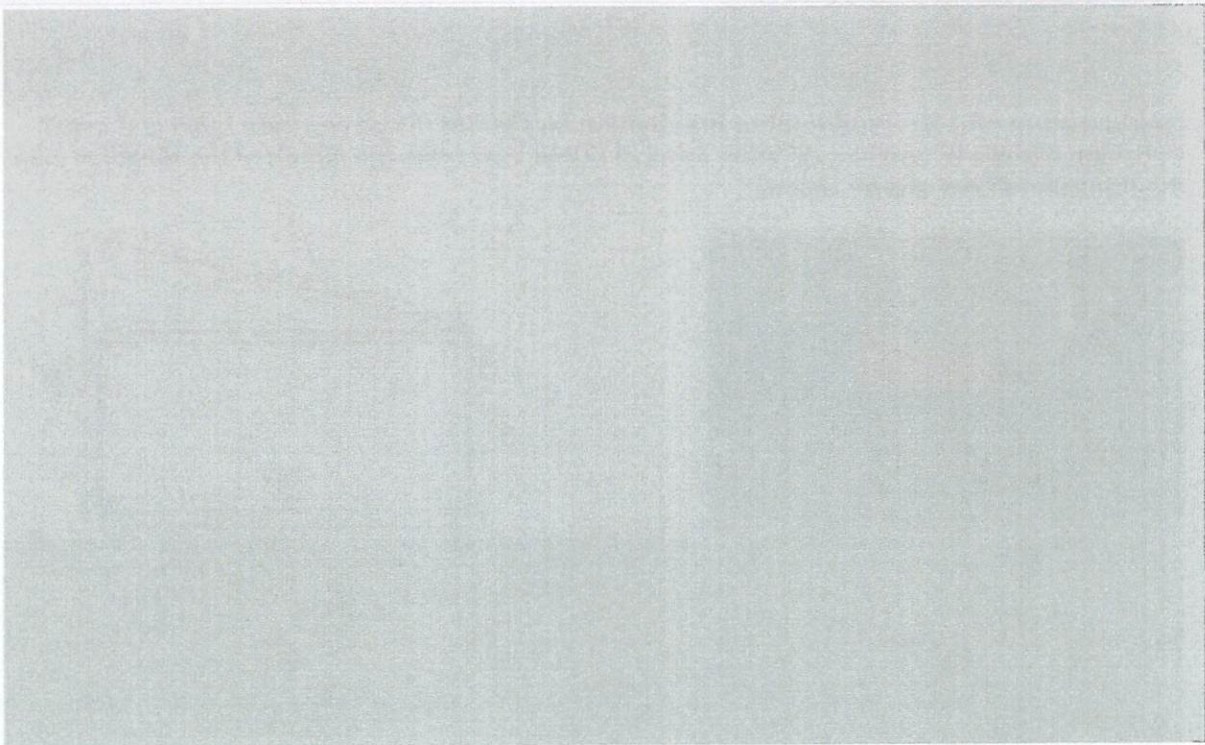

Using Drawings

Journeypersons working on a construction site follow specifications from a set of drawings or prints that show different views of the finished building project. Journeypersons in all trades scan the drawings for the detailed information they need.

Journeypersons often convert inches to fractions or decimals of a foot.

3 in. = $\frac{1}{4}$ ft. or 0.25 ft. 6 in. = $\frac{1}{2}$ ft. or 0.5 ft. 9 in. = $\frac{3}{4}$ ft. or 0.75 ft. 12 in. = 1.0 ft.

Adding and subtracting feet and inches:

Step 1: Line up the measurements so that like units are under like units.

Step 2: Add or subtract the inches. Add or subtract the feet.

Step 3: Change the inches to feet (divide by 12).

Step 4: Add your answer from step 3 to the number of feet from step 2.

Example:

Step 1	Step 2	Step 3	Step 4
$\begin{array}{r} 7 \text{ ft. } 11 \text{ in.} \\ + 2 \text{ ft. } 9 \text{ in.} \\ \hline \end{array}$	$\begin{array}{r} 7 \text{ ft. } 11 \text{ in.} \\ + 2 \text{ ft. } 9 \text{ in.} \\ \hline 9 \text{ ft. } 20 \text{ in.} \end{array}$	$20 \text{ in.} = 1 \text{ ft. } 8 \text{ in.}$	$\begin{array}{r} 9 \text{ ft.} \\ + 1 \text{ ft. } 8 \text{ in.} \\ \hline 10 \text{ ft. } 8 \text{ in.} \end{array}$

Look at the drawings for a residence on the next page to complete the questions below.

- The walk-in closet measures $1\frac{1}{4}$ in. \times $1\frac{1}{2}$ in. on the drawing. What are the actual dimensions of the closet?

- How many pocket (sliding) doors are needed?

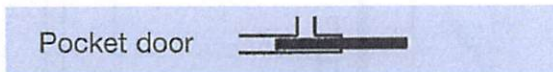

- What is the exterior length from (A) to (B)?

- Carpet costs \$28.50 per square yard. What is the cost of carpet for the master bedroom and closet?

1 yd.² = 9 ft.²

- Estimate the number of drywall sheets needed for the walls of the ensuite bathroom.

Drywall sheets: 4 ft. \times 8 ft.
Height of room: 8 ft.
Width of pocket door: 3 ft.

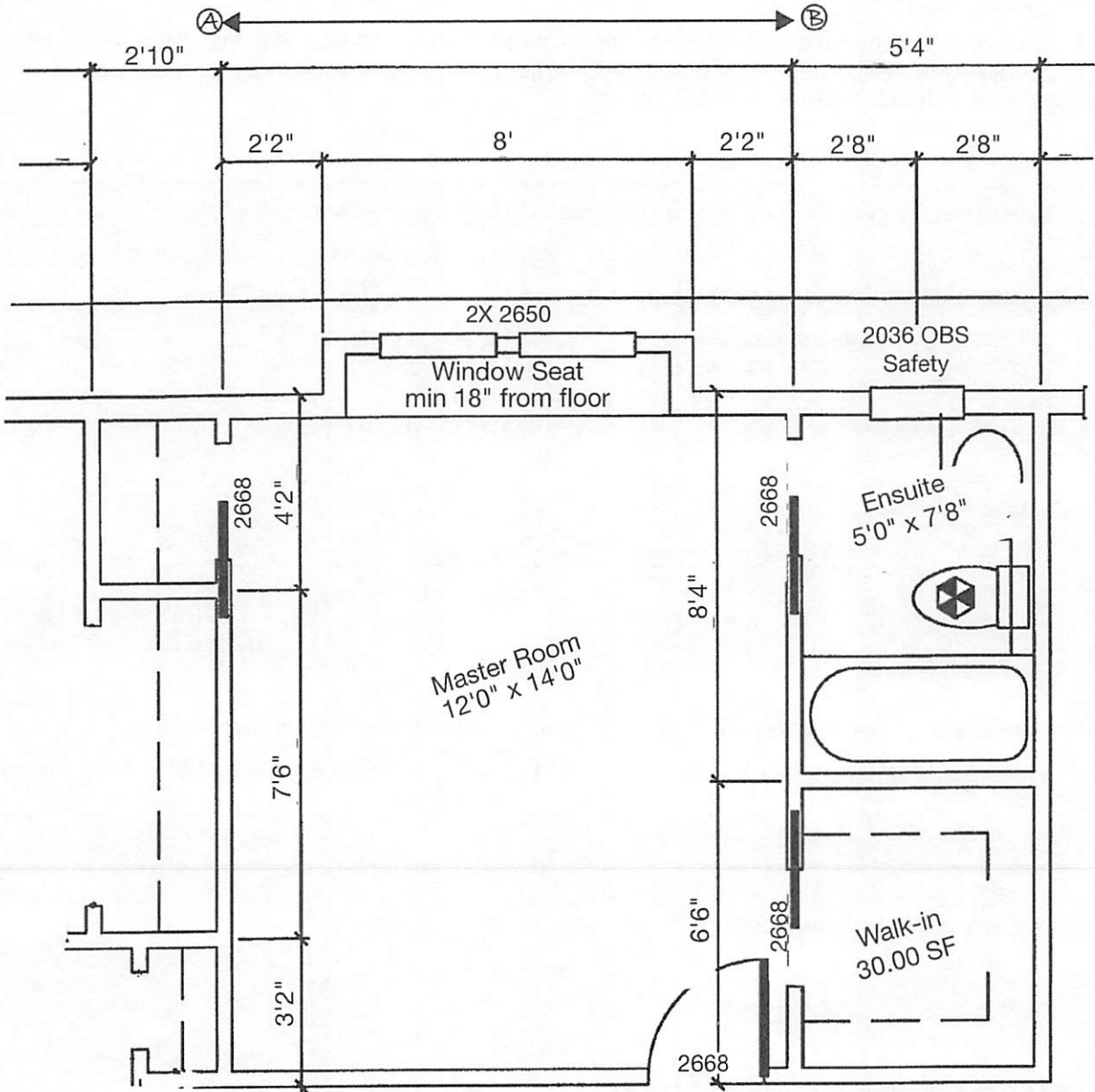

Of — A 3 sheet	Sheet	Date SEPT 20	
		Scale 1/4" = 1'0"	
		Job 2K1-09271	
		Drawn F	

Estimating Weight Loads

Mobile crane operators estimate weight loads. Calculating safe loads protects the equipment, the materials it carries, the workers on the job site and the general public.

Practice Exercise

Estimate the weight of a 4 ft. x 18 in. aluminum plate $\frac{3}{8}$ in. thick.
 Aluminum plate $\frac{1}{8}$ in. thick weighs approximately 1.75 pounds per square foot.

Steps:

1. Draw a diagram and label it with the measurements.

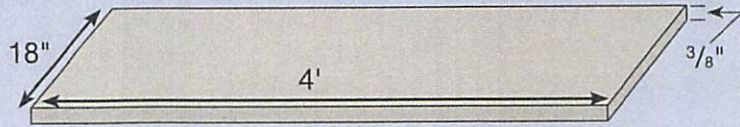

2. Calculate the area.

$$\begin{aligned} \text{Area} &= L \times W \\ &= 4 \text{ ft.} \times 1.5 \text{ ft.} \\ &= 6 \text{ ft.}^2 \end{aligned}$$

3. Calculate the weight.

a) **Weight of 1 ft.² of $\frac{3}{8}$ in. aluminum plate:** $\rightarrow \frac{3}{8} \text{ in.} \div \frac{1}{8} \text{ in.} = 3 \rightarrow 1.75 \text{ lb./ft.}^2 \times 3 = 5.25 \text{ lb./ft.}^2$

b) $\frac{\text{Area of plate}}{\text{Weight per square foot}}$ $= \text{Weight in pounds}$	$\frac{6 \text{ ft.}^2}{\times 5.25 \text{ lb./ft.}^2}$ $= 31.5 \text{ lb.}$	\rightarrow The aluminum plate weighs approximately 31.5 pounds.
--	---	--

1. **Boilermakers** and **ironworkers** estimate the weight of materials used in fabrication.
 Calculate the approximate weight of a 2 ft. x 18 ft. steel plate $\frac{3}{4}$ in. thick.

1" steel plate weighs about 40 lb./ft.².

2. A **mobile crane operator** estimates the weight of a concrete panel to make sure that the crane can lift it safely. Calculate the approximate weight of the panel shown below.

Reinforced concrete weighs about 150 lb./ft.³.

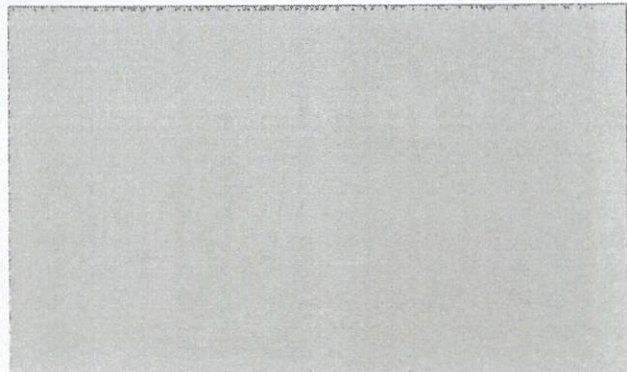
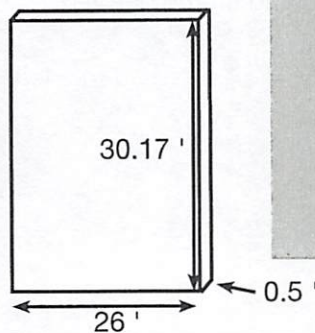

Working with Quantities

Rates and ratios are used to compare two quantities. Both can be expressed in the following forms: 1 to 2, 1:2 or $\frac{1}{2}$.

Rates compare two quantities with different units. For example, a rate can be used to describe the flow of a liquid in litres per second.

Example: 1 tablespoon of flour : 1 cup of milk

Ratios compare two quantities with the same units. For example, a ratio can be used to describe the number of parts of water and colouring agents to combine.

Example: $\frac{1 \text{ part water}}{2 \text{ parts cement}}$

Proportions compare two ratios or two rates.

1. A sewer line slopes at $\frac{1}{4}$ " per foot. Calculate the total fall in 30 feet.

Use this formula:
Total fall = length \times grade

2. **Automotive service technicians** occasionally need to convert kilometres to miles for American customers. An oil change is due at 35 000 km. What is the same distance in miles?

1 km = 0.6214 mi.

3. A **hairstylist** is mixing a hair treatment. The client has long hair, so the hairstylist starts with $1\frac{1}{4}$ scoops of powder lightener.

Mixing: Measure 1 level scoop of powder lightener into a non-metallic bowl or bottle. Add 1 oz. (30 g) of the booster and 2 fl. oz. (60 mL) of conditioning creme. Mix thoroughly to achieve a creamy consistency.

- a. Calculate the number of grams of booster needed.

- b. Calculate the number of millilitres of conditioning creme needed.

4. **Cooks** often change the yield of recipes to serve more or fewer customers. The following recipe makes 30 pancakes. Adapt the recipe to make 75 pancakes.

Use proportions to calculate how much of each ingredient is needed. The first ingredient is done for you using two different methods.

Method 1:

$$\frac{625 \text{ g}}{30} = \frac{? \text{ g}}{75}$$

$$\frac{625 \times 75}{30} = 46875 \div 30 = 1562.5 \text{ g}$$

Method 2:







$$625 \div 30 = 20.833$$

$$75 \times 20.833 = 1562.5 \text{ g}$$

Ingredient	Amount for 30	Amount for 75
Flour	625 g	1562.5 g
Sugar	60 g	
Baking powder	30 g	
Eggs	4	
Milk	1 L	
Melted butter	125 g	

5. Product labels provide information about quantities to mix. Use the label to answer the questions below it.

 = bag of concrete

POSTS (Standard fence)		2.5 x  = 1 Post
CONCRETE SLAB		5 x  = 6 sq.ft.
TUBE FORMS (For each 4' length)		5.5 x  = 10" Diameter 3.5 x  = 8" Diameter

- a. A carpenter is building a fence with 9 posts. How many bags of concrete are required to set the posts?

- b. Calculate the number of bags of concrete mix required for a slab measuring 5' x 2'4" x 6".

- c. Tube forms are used to form concrete columns. The concrete is mixed at a ratio of 2.5 litres of water per bag of concrete mix. Calculate the amount of water needed for a 15-foot column with a diameter of 8 inches.



Section 2: Money Math

Money math is used in paying and receiving money on the job, for example in handling cash, preparing bills or making payments. The following are three typical workplace examples of money math.

- **Cooks** use petty cash to purchase small quantities of supplies that are needed immediately.
- **Hairstylists** prepare bills and collect cash, debit and credit card payments for their services. They charge a set rate for each service and add applicable taxes, such as the GST.
- **Automotive service technicians** calculate the total cost of repair jobs including parts, labour, markup and taxes, and enter these amounts on estimates or finished work orders.

Calculating Increases and Decreases

Calculating increases

In some shops, products are bought at wholesale prices and marked up to sell to customers. Here is one way to calculate markup and sales tax.

Method	Examples
<p><i>Markup</i> $100\% + \text{markup} = \text{total } \%$ change % to a decimal $\text{total decimal} \times \text{unit price} = \text{selling price}$</p>	<p>An item with a wholesale price of \$14.35 is marked up 22%. Calculate the selling price.</p> $100\% + 22\% = 122\%$ $\frac{122}{100} = 1.22$ $1.22 \times \$14.35 = 17.507 = \17.51
<p><i>Sales tax</i> $100\% + \text{tax} = \% \text{ including tax}$ change % to a decimal $\text{total decimal} \times \text{cost} = \text{after-tax total}$</p>	<p>Calculate the after-tax cost of 2 hours of labour at a rate of \$45/hour.</p> $2 \text{ hours} \times \$45.00 = \$90.00 \text{ labour cost}$ $100\% + 7\% = 107\%$ $\frac{107}{100} = 1.07$ $1.07 \times \$90.00 = 96.3 = \96.30

Calculating discounts

Products are sometimes discounted when they are discontinued or when the supplier has a promotion. Here is one way to calculate a discount.

Method	Example
<p>$100\% - \% \text{ discount} = \text{new } \%$ change % to a decimal $\text{decimal} \times \text{unit price} = \text{sale price}$</p>	<p>An item with a regular price of \$10.89 is discounted 15%. Calculate the sale price.</p> $100\% - 15\% = 85\%$ $\frac{85}{100} = 0.85$ $0.85 \times \$10.89 = 9.257 = \9.26

1. In a hair salon, products are marked up for resale. Calculate the selling prices of the items listed below.

Wholesale price	Markup	Selling price
a. \$97.25	10%	
b. \$249.99	15%	
c. \$6.50	8%	

2. Calculate the after-tax cost of the items listed below.

Cost	Tax	Total
a. \$73.50	12%	
b. \$1,847.00	13%	
c. \$86.75	8%	

3. In a hair salon, products are discounted for promotions. Calculate the sale prices of the items listed below.

Price	Discount	Sale price
a. \$85.40	10%	
b. \$1,348.00	33%	
c. \$459.75	40%	

Invoicing for Services

Journeypersons who install, maintain and repair equipment often make invoices for services and are paid in cash, by cheque or by credit card on the job. Calculating tax is a typical task in these situations.

1. a) Complete the invoice on the next page for the following services:

- Repair dishwasher
- Model #MDB7601AWW
- Clean pump assembly, Test OK
- Labour 1.2 hours at \$88.25 per hour (5% GST)
- Parts \$2.80 (5% GST + 6% PST)

<p>McLean's Appliance and Refrigeration Ltd. 1529 Leopold St. Woodstock, ON N4S 1L2</p> <p style="text-align: right;">Invoice No. B0051441 Date: Nov. 15</p>			
Bill to: John B. Walker Phone: 519-555-2222 1250 Cloverley St. Woodstock, ON N4S 8M3			
Hours	Hourly rate	Description of work	Amount
		Subtotal	
		GST (#39706)	
		Total	

b) The customer pays the bill in cash using the following amounts:

- 1 × \$100
- 1 × \$20
- 1 cent

How much change should the technician give the customer? Enter the amounts of money that could be given as change in the table below. (There are several correct answers.)

\$50	\$20	\$10	\$5	\$2	\$1	25¢	10¢	5¢	1¢

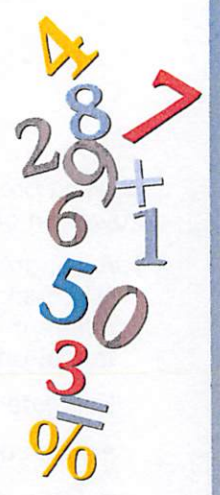

Section 3: Scheduling, Budgeting and Accounting

Scheduling, budgeting and accounting are used to manage time and money, for example in planning and keeping track of how you use your time and money, in choosing the products or services that offer the best value and in using your time and money wisely. The following are three typical workplace examples of scheduling, budgeting and accounting.

- **Industrial mechanics (millwrights)** schedule tasks for construction, repair and maintenance projects. They also create maintenance schedules for equipment in manufacturing plants.
- **Machinists** adjust daily work schedules to accommodate rush jobs or jobs that take longer than estimated. For example, they may change machining processes or the order of jobs. They consider whether others are affected by changes in the workflow and try to minimize the disruption.
- **Cooks** establish weekly budgets that include the cost of fresh food, shelf items and kitchen staff requirements. They also establish separate budgets for each of the catering events for the week. The costs included in the catering budgets vary depending on the menu items, number of courses and number of people served.

Comparing Values

Use a table structure to compare items.

Points of comparison	Item 1	Item 2	Item 3
Cost 1			
Cost 2			
Cost 3			

The problems in this section require you to locate and understand information in documents.

Coating products can be applied by either a trowel-on or a roll-on method.

1. A **concrete finisher** estimates the cost of resurfacing the sidewalk pictured using two different methods for placing concrete. The trowel-on method lasts longer but costs more.

Estimate the cost difference given:

- The concrete finisher charges \$37.50 per hour;
- Each coat takes approximately 1 hour and 30 minutes to apply.

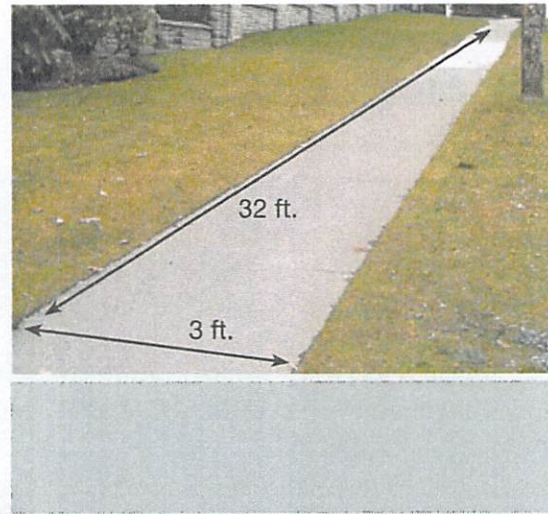

Roll-on Method

COMPONENT	9.29 m ² (100 sq. ft.)	18.58 m ² (200 sq. ft.)	27.87 m ² (300 sq. ft.)	37.16 m ² (400 sq. ft.)
NO PRIMER REQUIRED				
Step 1: Roll-on stone coat \$89.00/9.2 L	1 × 9.2 L	2 × 9.2 L	3 × 9.2 L	4 × 9.2 L
Step 2: Protective top coat \$26.78/946 mL	1 × 946 mL	2 × 946 mL	1 × 3.78 L	1 × 3.78 L

Trowel-on Method

COMPONENT	9.29 m ² (100 sq. ft.)	18.58 m ² (200 sq. ft.)	27.87 m ² (300 sq. ft.)	37.16 m ² (400 sq. ft.)
Step 1: Primer coat \$48.20/3.78 L	1 × 3.78 L	1 × 3.78 L + 1 × 946 mL	2 × 3.78 L	3 × 3.78 L
Step 2: Trowel-on stone coat \$115.07/15.1 L \$53.25/3.78 L	1 × 15.1 L + 2 × 3.78 L	3 × 15.1 L	4 × 15.1 L + 2 × 3.78 L	6 × 15.1 L
Step 3: Protective top coat \$26.78/946 mL	1 × 946 mL	2 × 946 mL	1 × 3.78 L	1 × 3.78 L

Accounting for Cost

Many journeypersons give estimates to customers. This involves telling the customer approximately how much he or she should expect to pay for a certain item.

In the example below, a journeyperson estimates that a sink will cost \$100. If the sink is not purchased or costs less than \$100, the savings are shown in brackets. This means the actual cost is less than budgeted.

Item	Allowance (\$)	Actual (\$)	Difference +/- (\$)
Sink	100.00	75.99	(24.01)

If the sink costs more than \$100, the extra cost is shown without brackets. This means the actual cost is more than budgeted.

Item	Allowance (\$)	Actual (\$)	Difference +/- (\$)
Sink	100.00	123.67	23.67

1. Journeypersons compare estimates with actual costs. When the customer selects the specific item they want to purchase, the journeyperson can point out how much higher or lower than estimated the actual cost will be.

Use the renovation invoice on the next page to answer the following questions.

- a. Compare the allowance for the floor coverings with the actual cost. Enter the difference on the invoice.

- b. A contractor is bidding on apartment renovations and needs to submit an estimate for installing the same bathroom mirror, wall tile and toilet in 5 units. Use the actual costs from the invoice to calculate the estimate the contractor should provide. Add 10% to account for rising costs.

Livingston Renovations

2709 Glenridge Avenue
Abbotsford, BC, V2S 4J5
604-123-4444

December 6

INVOICE – Allowances and Extras

Item	Allowance (\$)	Actual (\$)	Difference +/- (\$)
Exterior French doors	800.00	818.20	18.20
Fireplace & gas piping	1,800.00	1,850.00	50.00
Bathtub	250.00	153.00	(97.00)
Fireplace wall unit	4,000.00	5,585.00	1,585.00
Bathtub faucet & showerhead	150.00	0	(150.00)
Toilet	250.00	199.10	(50.90)
Sink	100.00	0	(100.00)
Faucet for sink	80.00	0	(80.00)
Bathroom vanity & countertop	450.00	1,020.00	570.00
Light fixtures & pot lights	650.00	650.00	0
Wall tile	150.00	145.12	(4.88)
Floor tile & carpet	3,050.00	6,356.03	
Bathroom mirror	50.00	0	(50.00)
Extra reframe around ducting	0	150.00	150.00
Extra install laundry cabinet	0	67.50	67.50
Surround speaker wire	0	35.00	35.00
Extra pot lights			n/c
ALLOWANCE BALANCE OWING			\$5,248.95



Section 4: Data Analysis

Data analysis is used to solve problems by analyzing and comparing data. The need for these skills is increasing as computer programs make data more available. The following are three typical workplace examples of data analysis.

- **Automotive service technicians** analyze readings from tests of vehicle electrical systems to diagnose problems such as an engine that will not start.
- **Machinists** review quality control data to examine trends in machine performance. For example, they may compare the finished dimensions of parts produced at different points in the machining cycle to decide when to replace tooling or recalibrate machinery.
- **Construction electricians** use the results of electrical measurements (e.g., draw, voltage, torque and temperature) taken at several points in a circuit to analyze circuit operation, to troubleshoot electrical problems and to increase electrical efficiency.

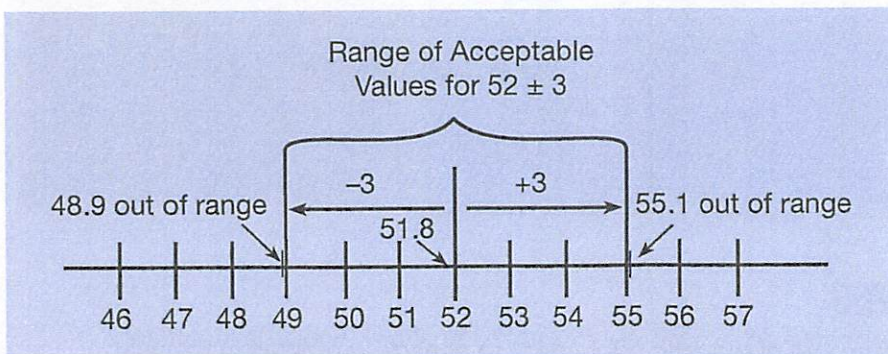



Calculating Tolerances

1. **Sheet metal workers, machinists, refrigeration and air conditioning mechanics** and others work to very tight tolerances. Decide if the measures in the following table are within specifications. If they are, place a ✓ in the table; if they are not acceptable, place an x.

± means plus or minus

Specification	Measure	✓/x	
a. $22.5^\circ \pm 2^\circ$	20.1°	<input type="radio"/> Acceptable	<input checked="" type="radio"/> Not Acceptable
b. $0.850 \text{ m} \pm 0.020 \text{ m}$	0.827 m	<input type="radio"/> Acceptable	<input checked="" type="radio"/> Not Acceptable
c. $0.750 \text{ L} \pm 0.015 \text{ L}$	0.761 L	<input type="radio"/> Acceptable	<input checked="" type="radio"/> Not Acceptable

2. An **ironworker** rigging a load plans to use a $\frac{3}{4}$ -inch wire-rope choker hitch to lift a beam that weighs 4.6 tons. Use the table below to make a recommendation for a safer lift. (There are several correct answers.)

WORKING LOADS FOR WIRE ROPES			
			
	Vertical Lift	Choker Hitch	Basket Hitch
Rope Size	Tons (2 000 lb.)		
1/4	0.60	0.45	1.20
3/8	1.34	1.00	2.65
1/2	2.40	1.80	4.80
5/8	3.50	2.60	7.00
3/4	5.40	4.00	10.80
7/8	7.00	5.20	14.00
1	9.10	6.80	18.20

Note: This capacity table is for this workbook only. On the job you should use the manufacturer's table.

Using Numbers in Patterns

1. **Automotive service technicians** use diagnostic equipment to analyze problems in exhaust systems. When the system is operating correctly, the Y or vertical axis on the graph should show signals that constantly change from under 0.2 volts to over 0.8 volts.

The graph below shows two sets of numerical data. The top set shows the reading from the driver's side of the engine and the bottom set shows the reading from the passenger's side.

How are the two sets of graph lines different?

